

**TEACHER-RELATED FACTORS IN INTEGRATING INFORMATION AND COMMUNICATION TECHNOLOGY IN SECONDARY EDUCATION: A PARTIAL LEAST SQUARES STRUCTURAL EQUATION MODELING APPROACH**

**Philip K. MWEI\*<sup>1</sup>, Lazarus M. OKIOMA<sup>2</sup> and Jackson K. TOO<sup>3</sup>**

<sup>1,2,3</sup> Department of Curriculum, Instruction and Educational Media, Moi University

**ABSTRACT**

This study compared integration of information and communication technology (as computer use) between secondary school mathematics and non-mathematics. A survey consisting of items on demographic information, computer use experience and five technology acceptance variables (computer self-efficacy, Teacher efficacy, Attitude towards computer, Social influence and Constructivist belief) was used for data collection. Data from 400 teacher respondents was used for analysis. WarpPLS 4.0 software was used to conduct the analyses for PLS-SEM and Multigroup comparison using MS Excel. Results show that computer self-efficacy had significant direct effect on computer use; moderated by age and computer experience for mathematics and non-mathematics teachers respectively. Teacher efficacy had a negative significant relationship with computer use for mathematics teacher sub-sample moderated by gender and age. Attitude towards computer had a positive total effect on computer use for the mathematics teacher sub-sample mediated by computer self-efficacy and moderated by gender. Social influence had a significant positive total effect on computer use for the non-mathematics teacher sub-sample moderated by age. Constructivist belief revealed inconsistent relationship with computer use (positive for non-mathematics teacher sub-sample and negative for mathematics teacher sample) with computer self-efficacy as a mediator of this relationship in the non-mathematics teacher sample.

**KEYWORDS:** ICT integration, secondary school teachers, self-efficacy, attitude towards computer, social influence, constructivist beliefs.

**Contribution/Originality:** This study contributes to the existing literature and discourse in the integration of ICT in education. It also contributes to the understanding of salient teacher-related variables that influence their readiness to make use of ICT in pedagogical practices.

**1. INTRODUCTION**

Information and communication technology (ICT) is a fundamental aspect in the knowledge economy and the information society of the 21<sup>st</sup> century. Its pivotal role in supporting the overall human progressive is evident in both developed and developing economies. Education, for example, is one of the main recipient of the evolution of ICT software and hardware, benefiting most from the connectedness afforded by ICT networks which have considerably enhanced efficiency in communication and knowledge representation and presentation. All education cycles from early childhood to tertiary/higher education have adopted the use of ICT for academic, financial and

general management of these institutions. As an instructional tool, ICT has gradually demonstrated its efficacy based on experimental studies on learning outcomes. In the developing world, the availability of these ICT tools to schools has increased and many governments have developed policies which demand the integration of ICT in pedagogy at all levels of education as the key enabler of learning.

Teachers' ICT capabilities are necessary (though not sufficient) in the process of ICT integration as acknowledged by a variety of countries and organizations both international and local (Markauskaite, 2007). This implies that teachers play a crucial part in the use of ICTs in education as agents and catalysts of curriculum change and innovation, and the instructional process (Afshari, Bakar, Luan, Samah & Fooi, 2009; Gulbahar & Guven, 2008; Omoniyi & Quadri, 2013). The UNESCO (UNESCO, 2008; UNESCO Bangkok, 2005) has recognized the role of ICTs in education. Guidelines on the requirements to integrate ICT ranging from hardware and software to teacher and student performance standards have consequently been outlined.

For instance, in Kenya, the Ministry of Education, MoE (2006) stipulates the need for ICT integration particularly to secondary and primary schools, and especially to support free primary education. Policies and programs on the need to infuse ICT into education exist, for instance the Sessional Paper No. 1 of 2005, Kenya Vision 2030, Kenya Education Sector Support Program (KESSP) and the Economic stimulus Program (ESP) front the use of ICTs in curriculum and instruction (MoEST, 2005; MoIC, 2006). The focus of these policies is on infrastructure, curriculum and training. A training centre, the National ICT Innovation and Integration Centre (NI<sup>3</sup>C) was established in Nairobi in the former Kenya Science Teachers College, with full-time staff as a teacher training centre. The NI<sup>3</sup>C has managed to train a number of ICT champions (teachers considered as "master integrators") for a number of secondary schools nationally. The NI<sup>3</sup>C idea was a collaboration of the Government of Kenya through Ministry of Education and the Government of Belgium through VVOB (Flemish Development Cooperation).

To say ICT integration in education is inevitable is an understatement, it is a "heart beat" of education itself. It is without doubt that teachers form one pillar in this endeavor, and to understand teachers' contribution, studies have and continue to be conducted to establish the specific factors that lead to successful integration of ICT in education. This study is one such effort.

## **2. THEORETICAL BACKGROUND**

### *2.1. Theories Underpinning the Study*

This study made reference to three theories: the Theory of Reasoned Action (TRA) of Ajzen and Fishbein (1975, Venkatesh, Morris, Davis & Davis, 2003; Yilmaz & Ozer, 2013), Social Cognitive Theory (SCT) of Bandura (1977, Venkatesh et al., 2003) and constructivist theory. Theory of Reasoned Action (TRA) was derived from psychology being used to measure behavioral intention and performance with two constructs (latent variables): attitude and subjective norm. TRA proposes

that the *behavioural intention* of an individual to perform (or not to perform) a certain target behaviour, is solely and directly responsible for influencing that individual's *target behaviour* (Ajzen, 2002). In turn, an individual's *behavioural intention* is said to be jointly determined by two factors: *attitude towards behaviour* and *subjective norm* (Venkatesh et al., 2003). *Attitude towards behaviour* can be described as an individual's subjective forecast of how positive or negative he/she will feel when performing the target behaviour, whereas *subjective norm* (that is, social influence, Venkatesh et al. 2003) can be viewed as an individual's perception of the social pressure on him/her to perform the target behaviour. "Theory of Reasoned Action posits that if a person has more positive attitudes and subjective norms towards certain behavior; it is more likely for that person to have positive intention towards behavior in question" (Yilmaz & Ozer, 2013, p.111).

Social cognitive theory addresses how humans, as individuals and as members of groups, exercise some level of control over their futures (Goddard, Hoy & Woolfolk, 2004). When individuals or groups believe themselves capable of certain attainments, they are more likely to approach their goals with creativity, effort and persistence that can lead to success (Goddard & Skrla, 2006). SCT postulates that efficacy beliefs are based on one's thoughts about past enactive and vicarious experiences, and the social persuasion of individuals and organizations that have the potential to strengthen teachers self-and collective-efficacy beliefs. This study makes use of self-efficacy in two forms: teacher general sense of efficacy (or teacher efficacy; Teo, 2010) and computer self-efficacy (Compeau & Higgins, 1995).

Constructivist theory is based on the belief that the learner's mind actively contributes to knowledge construction directly from experience, that is, a priori, not passively organizing experiences presented to him/her (Smeets, van Gennip, & van Rens, 2009; Tondeur, Valcke, & van Braak, 2008). Accordingly constructivism contends that learning is an active process involving learner construction and reconstruction of knowledge, and teacher's role as that of guiding and facilitating learners in the process (Lim & Chan, 2007). Constructivist pedagogical belief as pertains to the teacher's role in relation to learner construction of knowledge is utilized in this study (Woolley, Benjamin & Woolley, 2004). This belief is based on learner-centered teaching-learning strategies such as beliefs about expanding on learner ideas, involving learners in evaluation of their work and involvement in group work.

In guiding this study, TRA, SCT and constructivist theory were incorporated into a conceptual framework (a research model). From the TRA, social influence (that is, a variant of subjective norm) and attitudes towards computer (computer attitude) were included. A decision was made to exclude behavioural intention, informed by the criticisms of TRA on the weakness of behavioural intention construct (Bagozzi, 2007; Venkatesh, Davis & Morris, 2007). The concept of self-efficacy from the SCT was included after considering two surrogate constructs: teacher efficacy (or general efficacy) and teacher computer self-efficacy. Finally, from the constructivist theory, a set of constructivist pedagogical beliefs were used as "constructivist belief" construct.

2.2. Conceptualizing the Research Model

From the theoretical framework, three theories: TRA, SCT and constructivist theory, were merged into a conceptual framework. In this study, teacher-related factors that were considered most important and have been researched more often in isolation were selected. The five independent variables (or technology acceptance variables) are: Computer Self-Efficacy, Teacher Efficacy, Computer Attitude, Social influence and Constructivist belief and three moderators (gender, age and computer experience).

All technology acceptance variables were hypothesized to have direct effect on computer use moderated by gender and age (and computer experience for computer self-Efficacy and computer attitude). Teacher efficacy, computer attitude, social influence and constructivist pedagogical beliefs were postulated to have indirect effect on computer use through computer self-efficacy. Finally, computer attitude was proposed to mediate the effect of social influence and constructivist pedagogical belief on computer use (Figure 1).

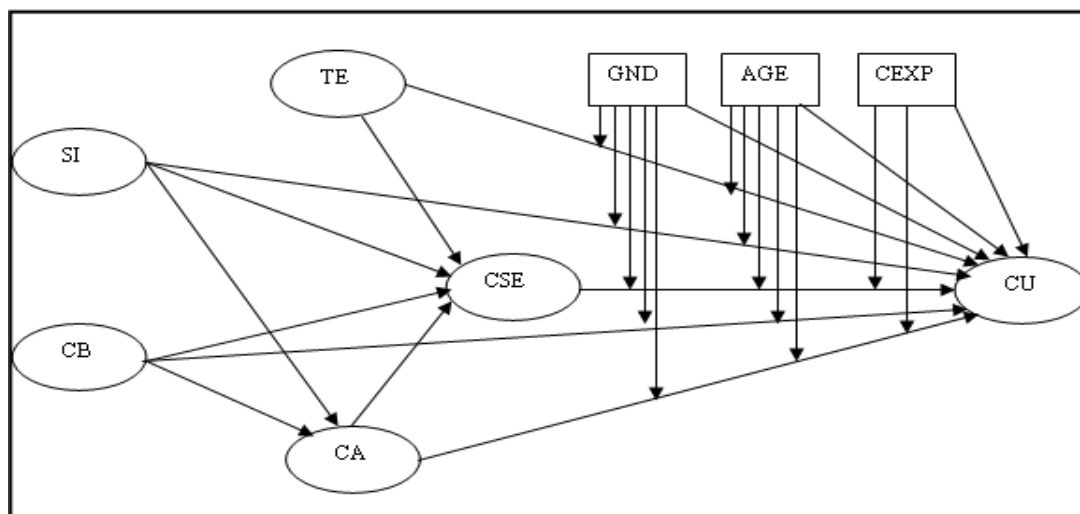

Figure 1. Conceptual Framework of the Study

Notes: Independent Variables: CA = Computer Attitude, CB = Constructivist Belief, CSE = Computer Self-Efficacy, SI = Social Influence, TE= Teacher Efficacy; Dependent Variable: CU = Computer Use; Moderator Variables: GND = Gender, AGE, CEXP = Computer Experience

3. LITERATURE REVIEW

3.1. Self-Efficacy and Computer Use

Self-efficacy can be used to explain technology usage behaviours (Teo, 2009a). Specifically, computer self-efficacy reflects a teacher’s belief in his/her ability to perform computer-based instructional tasks (Tsai, Chuang, Liang and Tsai, 2011). Ross, Hogaboam-Gray and Hanney, (2001)

bring learner dimension into the definition of computer self-efficacy as “teacher expectation that he or she will be able to bring about student learning” (p. 142).

Pre-service teachers’ computer self-efficacy has been viewed as a multidimensional construct underlying three dimensions related to: Basic computer skills, media-related skills, and web-related skills (Teo & Koh, 2010). Teo (2009b) examined the relationship between computer self-efficacy and intended uses of technology of student teachers assessed by three factors: Basic Teaching Skills, Advanced Teaching Skills, and Technology for Pedagogy. For pre-service teachers, their computer self-efficacy significantly predicted their ability to integrate technology use in the classroom (Sang, Valcke, Van Braak, Tondeur & Zhu, 2010).

Compeau and Higgins (1995) found that individuals with higher computer self-efficacy beliefs tend to see themselves as able to use computer technology. Those with lower computer self-efficacy beliefs tend to become more frustrated and anxious when working with computers; and hesitate to use computers when they encounter obstacles. Therefore, teachers’ computer self-efficacy is a significant factor determining their patterns of computer use (Al Dafaiei, Ismail, Sansuidin & Shakir, 2013; Deryakulu, Buyukozturk, Karadeniz & Olkun, 2009; Sang et al., 2010).

According to Sang et al. (2010), self-efficacy was characterized as major mediator of behaviour, and more importantly, that of behavioural change. Individuals who perceive themselves as capable of performing certain tasks or activities are defined as being high in self-efficacy, and are more likely to attempt these tasks and activities; and vice versa. Bruce and Ross (2008) assert that teacher efficacy is the central mediator between experience and action. Experienced teachers are less ready to integrate ICT (Baek, Jung & Kim, 2008). Bao, Xiong, Hu and Kibelloh (2013) established significant gender difference on computer self-efficacy affecting computer use.

### *3.2. Teacher Computer Attitude and Computer use*

Users’ attitudes towards either accepting or rejecting ICT have been studied by different researchers (Abukhazam & Lee, 2010; Rajasekar & Raja, 2007). Findings indicate significant positive relationship between computer attitude and ICT usage (Al Dafaiei et al., 2013; Kumar, Rose & D’Silva, 2008; Rastogi & Malhotra, 2013; Shin, Han & Kim, 2014; Wozney, Venkatesh & Albrini, 2006). Positive attitudes are predictive of increased computer use in different settings such as in companies, banking and schools (Birisci, Metin, & Karakas, 2009). Some other studies have found non-significant relationship between computer attitude and computer use (Mulwa & Kyalo, 2013; Rahimi & Yadollahi, 2011).

A number of studies on computer attitude have taken into account possible third variables that can moderate or mediate attitude towards ICT and computer use. In different studies, several factors that could moderate or mediate the effect of computer attitude on computer use have been identified. These factors as identified are: gender, age, experience/seniority, specialization (grade level and

subject areas). For gender, differences on computer attitude have been reported (Jegede, 2008; Ocak, 2005), male teachers are more positive than female teachers (Papanastasiou & Angeli, 2008) and in others no effect were found (Wozney et al., 2006; Kurgat, 2011; Rajasekar & Raja, 2007). Positive computer attitude have been found to decrease with age (Hung & Hsu, 2007; Ocak, 2005) while in others age had non-significant influence on computer attitude (Kurgat, 2011). The more experienced users generally hold less positive computer attitude (Hung & Hsu, 2007; Kutluca, 2011).

The differential role played by third variables on computer attitude does not afford generalizability of findings to different geographical and cultural settings. This is because sociopolitical, economic and technological advancement in different countries seem to explain these findings.

### *3.3. Social Influence and Computer use*

Venkatesh et al. (2003) hypothesized indirect effect of social influence on users of computer technology through behavioural intention. Specifically, gender, age, voluntariness and computer experience were postulated as moderators of the effect of social influence on behavioural intention. For technology users, social influence and attitudes have a (direct) positive relationship between them. Similarly, Teo, Lee and Chai (2008) found that social influence had both a direct and indirect effect on computer attitude for student-teachers.

Weaknesses have been identified and reported in the behavioural intention construct (Bagozzi, 2007; Bandura, 2001; Venkatesh et al., 2007). Bandura (2001) observes that intentions and actions are separated in time. With this observation, there is room for varied intervening steps, both positive and negative, in order to enhance or dampen the direct effect of intentions on action or behaviour. In this study, social influence is hypothesized to have: direct, indirect and moderated (with gender and age) effect on computer use.

### *3.4. Pedagogical Beliefs and Computer Use*

Research studies have pointed out a relationship between teacher's pedagogical beliefs and computer integration (Chen & Reimer, 2009). The use of open-ended applications fits into constructivist pedagogical practices (Sang, Valcke, van Braak & Tondeur, 2009; Smeets et al., 2009; Tondeur, van Braak, & Valcke, 2007). Teo, Chai, Hung, and Lee (2008) conducted a study on student teachers' beliefs and found that constructivist teaching is positively correlated to use of ICT. In contrast, Khader (2012) established non-significant relationship between pedagogical beliefs and classroom practices.

Lim and Chai (2008) investigated (observed and interviewed) six teachers from two primary schools, the teachers accounted for the inconsistency between their espoused beliefs (five constructivists) and the traditional teaching practice as due to contextual constraints such as pressure on syllabus coverage for examination preparation.

Lim and Chai (2008) opine on the possibility of different teacher pedagogical beliefs having significant impact on different approaches to the planning and conduct of lessons. For instance, Baser and Mutlu (2011) found a significant relationship between gender and pedagogical beliefs, female teachers were more likely to be constructivist than their male counterparts. However, no significant differences between pedagogical beliefs and gender of primary school teachers were observed (Hermans, Tondeur, van Braak & Valcke, 2008; Sang et al., 2009). Smeets et al. (2009) found significant relationship between subject disciplines (science/technical and languages) and use of ICT for transfer of knowledge (traditional beliefs). Teacher beliefs and their practices may be related to prior experience both in and outside schools (Bingimlas & Hanrahan, 2010).

Bingimlas and Hanrahan (2010) on a review of teacher beliefs and practices indicate that a direct relationship between the two has been questioned (Lim & Chai, 2008) thus: “[T]he question may be asked as to whether teacher practice is necessarily consistent with teacher beliefs” (p.421). They however attribute this anomaly to the variety of definitions in the literature and came up with the following three perspectives on the relationship between teacher beliefs and teacher practice: (a) teacher beliefs as influential on their practice, (b) teacher beliefs as a weak influence on their practice, and (c) the relationship between teacher beliefs and their practices is a complex one. These perspectives however, leave the research community at crossroads, not certain which direction prior results point and accordingly a call for more evidence is warranted.

Mismatch or disconnectedness between teachers’ beliefs, their practices and general classroom reality have been observed as due to the influence of external and internal factors. If these factors match teacher beliefs, classroom practice and beliefs are attuned, otherwise, teacher beliefs and classroom practice are disjointed (Bate, 2010; Chen, 2008; Liu, 2011; Handal & Herrington, 2003; Mansour, 2009). It is proposed that this observations point strongly to the effect of third variables. Therefore, the notion of “technology is good” (Windschitl & Sahl, 2002), is not sufficient to encourage teachers’ computer integration into their classroom practice. Implementing ICT in education is a complex endeavor shaped by pedagogical philosophies (Granger, Morbey, Lotherington, Owston, & Wideman, 2002).

## **4. MATERIALS AND METHODS**

### *4.1. Research Objectives*

This study aimed to determine the effect of mathematics and non-mathematics teachers’ computer self-efficacy, general efficacy, computer attitude, constructivist beliefs and social influence on computer use for pedagogy and whether teacher’s gender, age and computer experience moderate this effect.

### *4.2. Research Hypotheses*

Hypotheses were derived for each technology acceptance variable (or independent variable) and respective moderators (gender, age or computer experience). The five main research hypotheses are as follows:

HA<sub>1</sub>: Mathematics and non-mathematics teacher's gender, age and computer experience moderate the positive relationship between teacher's computer self-efficacy and computer use for pedagogy.

HA<sub>2</sub>: Mathematics and non-mathematics teacher's gender and age moderate the negative relationship between teacher's general efficacy and computer use for pedagogy.

HA<sub>3</sub>: Mathematics and non-mathematics teacher's gender, age and computer experience moderate the positive relationship between teacher's computer attitude and computer use for pedagogy.

HA<sub>4</sub>: Mathematics and non-mathematics teacher's gender and age moderate the positive relationship between teacher's perceived social influence and computer use for pedagogy.

HA<sub>5</sub>: Mathematics and non-mathematics teacher's gender and age moderate the positive relationship between teacher's constructivist belief and computer use for pedagogy.

### 4.3. Study Area

This study was conducted in eight sub-counties in the North Rift Valley region of Kenya. Five schools from each sub-county were included.

### 4.4. Sampling and Sample Size Determination

Sample size determination in PLS-SEM has not led to a single agreed "rule of thumb." This study used Westland (2010) suggested formula. This formula takes into account the number of variables and their indicators involved in a study where the minimum sample size ( $n$ ) is given by the relation:

$$n \geq 50r^2 - 450r + 1100 \text{ and } r = \frac{p}{k}, p = \text{the number of indicators and } k = \text{the number of LVs.}$$

This study has five independent variables (computer self-efficacy = 6 indicators, teacher general efficacy = 7 indicators, computer attitude = four indicators, perceived social influence = four indicators and constructivist belief = 6 indicators), one dependent variable (computer use = 15 indicators) and three moderators (Three indicators) to be modeled for both mathematics and non-mathematics teacher subsamples. The total number of Moderator by IV results to 12 LVs with a total of 64 indicators. Therefore, the number of indicators,  $p = 109$  while the number of variables,  $k = 21$ . Therefore,  $r = 5.2$  and the sample size expected is  $n \geq 50 \times 5.2 \times 5.2 - 450 \times 5.2 + 1100 = 112$ , rounded to 120 (as "more is always better", Fabrigar, MacCallum, Wegere & Strahan, 1999; Osborne & Costello, 2004). The minimum sample size for each teacher subsample should be 120 respondents and this value was used to calculate the final sample size after taking into account expected response rate.

To obtain the number of the "actual sample" selected, the percentage expected response rate was taken into account to calculate the sample size of the mathematics and non-mathematics teachers. As Baruch and Holton (2008) observe that, "it should be noted that the [response rate] RR is just one element to consider in evaluating the quality of empirical studies" (p. 1153). A number of authors have suggested acceptable minimum response rate for mailed questionnaire as ranges between 50% and as high as 80%. Baruch and Hilton (2008) suggest a minimum of 50% with caution that "any



deviation from these benchmarks, *especially downwards* [emphasis added], should be explained” (p.115) while Nulty (2008) and Fincham (2008) agree to a recommended (acceptable) minimum response rate of 70%.

This study, therefore, used an expected response rate of 70%. Furthermore, from pilot study, it was established that the number of non-mathematics teachers to mathematics teacher was at least 2:1 (non-mathematics teachers are at least twice as more as mathematics teachers). Finally, the sample sizes were calculated as follows: non-mathematics teachers,  $n = (120 \times 100\%) / 70\% = 171$  and non-mathematics teachers,  $n = [(120 \times 100\%) / 70\%] \times 2 = 342$ . The combined sample size was 513.

#### 4.5. Research Instrument

This study used a self-administered questionnaire. This instrument consisted of (a) items that sought teacher’s demographics and experiences, and a combination of scales for the five independent variables (see Mwei, 2020, p. 29 for more details) and (b) a scale for the dependent variable, Computer Use for Pedagogy (CU) Scale (see Mwei, Too & Okioma, 2019, p. 8 for more details). The Computer Scale consisted of 13 Five-point Likert-type items, ranging from 0 = *never* to 4 = *always*. The CU items come from: computer use for teaching, TTCU; computer use for learning, SLCU and computer use for basic skills, SKCU.

#### 4.6. Data Analysis

Descriptive statistics for computer use scale are presented and discussed for independent variables in Mwei (2020). PLS-SEM analysis served a confirmatory role for the second order computer use variable (reflective latent variable, LV) besides testing the hypotheses. The three first order reflective latent variables (computer use for teaching, TTCU; computer use for learning, SLCU and computer use for basic skills, SKCU) obtained from factor analysis with pilot data (Mwei et al. 2019) were used to build the computer use latent variable (second order dependent variable). A “two-stage” creation of a second order computer use LV from the three first order LVs was followed (Leon, 2012; Kock, 2010a) in PLS-SEM using WarpPLS 4.0 software. Model assessment (measurement and structural) were conducted, testing for measurement invariance and structural model differences.

## 5. RESULTS

### 5.1. Descriptive Statistics

This study achieved a response/return rate of 81.3% (417 questionnaires, 134 (78.4%) of mathematics and 283 (82.7%) of non-mathematics) was achieved with 402 usable questionnaires (128 mathematics and 272 non-mathematics), 15 (3.6% of the returned questionnaires) were rejected because they were incomplete with missing demographic information or other non-response to items in the questionnaire. Further, two questionnaires were rejected by PLS-SEM analysis as outliers (with respect to computer experience).

We report the means, standard deviations and correlations for computer use items in the computer use scale (see Mwei et al. 2019) presented in Table 1. The means and standard deviations for the independent variables (computer self-efficacy, teacher efficacy, attitude towards computer, constructivist beliefs and social influence) are presented in Mwei (2020).

From Table 1 we deduce; first, basing on an equal interval of computer use items (a) five items have a mean  $0.8 < M \leq 1.6$ , that falls on the *rarely* used category, (b) six items have a mean,  $1.6 < M \leq 2.4$ , that falls on the *sometimes* used category, and (c) three items have a mean,  $2.4 < M \leq 3.2$ , that falls on the *very often* used category. Second, all correlations are significant at  $p < .01$ . Note however, correlations are affected by sample size such that the larger the size of the sample, small correlation coefficients (in absolute terms) may become significant. Therefore, reporting and interpreting the size of correlations were necessary. According to a proposal by Taylor (1990) on a review of reported correlations in empirical studies, presented the following ranges to interpret the strength of correlation coefficients:  $\leq 0.35$  as low or weak correlations, between 0.36 and 0.67 as modest or moderate correlations, between 0.68 and 0.90 as strong or high correlations, and  $> 0.90$  as very high correlations. The majority of these correlations fall within the modest or moderate levels. Third, based on a modified thinking, correlations  $\geq 0.60$  are underlined in Table 1, to highlight fairly strong correlations. This implies that the correlation of  $\geq 0.60$  between any two items determines at least 36% of shared variance. Some of the correlations are as high as 0.80, explaining at least 64% of the variance shared between the two corresponding items. It can be seen that the correlations of items in each construct are  $\geq 0.60$  which are fairly modest to strong correlations (Taylor, 1990).

**Table 1. Means, Standard Deviations and Correlations of Computer Use Items**

CU	CU												
	SL1	SL2	SL3	SL4	SL5	SL6	TT1	TT2	TT3	TT4	SK1	SK2	SK3
SL1	1												
SL2	<u>.82</u>	1											
SL3	<u>.63</u>	<u>.67</u>	1										
SL4	<u>.66</u>	<u>.78</u>	<u>.81</u>	1									
SL5	<u>.62</u>	<u>.65</u>	.59	<u>.63</u>	1								
SL6	<u>.68</u>	<u>.71</u>	<u>.78</u>	<u>.76</u>	<u>.80</u>	1							
TT1	.50	.47	.34	.40	.49	.47	1						
TT2	.32	.30	.18	.24	.34	.29	<u>.63</u>	1					
TT3	.49	.42	.25	.31	.44	.43	<u>.83</u>	<u>.62</u>	1				
TT4	.39	.38	.19	.27	.42	.38	<u>.79</u>	<u>.79</u>	<u>.79</u>	1			
SK1	.51	.55	.47	.55	.49	.53	.49	.28	.42	.37	1		
SK2	.35	.37	.31	.39	.32	.36	.38	.28	.35	.37	<u>.66</u>	1	
SK3	.41	.45	.41	.48	.42	.44	.48	.28	.41	.36	<u>.80</u>	<u>.67</u>	1

---

<i>M</i>	1.11	1.36	1.20	1.93	1.30	1.90	2.39	2.21	1.68	2.51	2.06	2.75	1.42
<i>SD</i>	1.23	1.25	1.30	0.83	1.30	0.86	0.88	1.50	1.38	0.98	0.97	0.83	1.39

---

Note: CU = Computer use; SL1 - 6 = Computer Use as a Learning Tool (SLCU) items; TT1 - 4 = Computer Use as a Teaching Tool (TTCU) items; SK1 - 3 = Computer Use for Basic Skills (SKCU) items. All correlations are significant at  $p < .01$  level (2-tailed). Correlation coefficients whose magnitude is  $\geq .60$  are underlined.

### 5.2. Model Assessment

We describe assessment of measurement and structural models. The measurement model assessment tested whether the indicators for any latent variable (LV, independent and dependent variables) met the minimum requirements for the appropriateness of sample data while the structural model gave information on the hypothesized relationships in the SEM analysis. The five basic steps of conducting a PLS-SEM using WarpPLS 4.0 were followed (for detailed information, consult Kock, 2010b).

#### 5.2.1. Measurement Model Assessment

The measurement model defined the latent variables (LVs) or constructs that the model used (independent and dependent variables) and assigned indicators or items to each (Diamantopoulos, Riefler & Roth, 2008; Henseler, Ringle & Sinkovics, 2009). The measurement model attempted to analyze whether theoretical constructs (variables in the study) were correctly measured by the items or indicators. PLS-SEM measurement model can either be reflective or formative (Diamantopoulos et al., 2008; Franke, Preacher & Rigdon, 2008; Kline, 2012).

This study used a reflective measurement model. The reflective model has causal relationships from the independent variables to the items or indicators. That is, the direction of causality is from the construct (LV) to the indicator; thus, indicators are assumed to reflect variation in the latent variable (Franke et al., 2008; Henseler et al., 2009; Jarvis, Mackenzie & Podsakoff, 2003; Kline, 2012). In applying the reflective measurement model, this study assumed that the items in the questionnaire “reflected” the variation in their corresponding latent variables (the predictors and computer use).

Furthermore, computer use was modeled as a reflective second-order construct (Jarvis et al., 2003). First, using the three dimensions of computer use, three first order reflective latent variables were created (SLCU, TTCU and SKCU). The three latent variables of computer use formed a second order reflective LV, the “computer use” as a multidimensional construct. Measurement model assessment provided evidence on whether the LVs were correctly measured by the indicators or manifest variables or items (Barroso et al., 2010; Henseler et al., 2009). Secondly, computer use was considered a reflective second-order construct created from the three first order computer use LVs (second-order LV; see Leon, 2012 on how second-order constructs are formed using WarpPLS). The

predictor LVs: computer self-efficacy, teacher efficacy, computer attitude, constructivist belief and social influence were considered reflective first-order LVs.

5.2.2. Validity Assessment

The measurement model for the latent variables validity was assessed. A confirmatory factor analysis (Ringle, Sarstedt & Straub, 2012) with principal components as a means of extraction and oblique rotation (Kock, 2011) was conducted using WarpPLS 4.0 (Kock, 2013a). Confirmatory factor analysis was used to establish whether discriminant validity and convergent validity met the acceptable thresholds (Gefen & Straub, 2005) to enable SEM analysis. Loadings of all indicators (manifest variables) were greater than 0.5 on the hypothesized component (latent variable) and they were also significant with  $p < .05$  (Fornell & Larcker, 1981; Gefen & Straub, 2005).

Table 2 shows loadings, cross-loadings and the probabilities ( $p$  values) obtained from the confirmatory factor analysis for all latent variables used in this study for the two samples (mathematics and non-mathematics teachers) respectively. All standardized factor loadings are not rotated and the cross-loadings are after an oblique rotation (Kock, 2011, 2013a). This type of rotation (oblique) is recommended in SEM as LVs are anticipated to correlate with each other (Kock, 2011). This oblique rotation was necessary in order to anticipate a logical hypothesis of a second-order computer use (related components).

Two of the Teacher Efficacy items (indicators) and one item of the Constructivist Belief did not load properly in either sample; therefore these indicators were removed from the study because their values were less than the 0.5 minimum level required. All the standardized factor loadings included in this study were significant at  $p < .001$  (Table 2). These loadings indicate that the research instrument had sufficient convergent validity (Gefen & Straub, 2005; Henseler et al., 2009). This meant that the indicators loaded sufficiently on their corresponding latent variables as were proposed. Subsequently, all the LVs (computer use, computer self-efficacy, computer attitude, teacher efficacy, social influence and constructivist belief) were well defined.

**Table 2. Loadings and Cross-Loadings for LVs for Two Teacher Subsamples**

	CU	CSE	TE	CA	CB	SI
SLCU	(0.802) <b>(0.847)</b>	0.161 <b>-0.010</b>	-0.077 <b>0.058</b>	-0.066 <b>-0.034</b>	-0.047 <b>-0.028</b>	-0.054 <b>0.082</b>
TTCU	(0.776) <b>(0.780)</b>	-0.181 <b>-0.031</b>	0.156 <b>0.009</b>	0.071 <b>0.052</b>	0.103 <b>-0.002</b>	-0.004 <b>-0.003</b>
SKCU	(0.808) <b>(0.845)</b>	0.014 <b>0.039</b>	-0.073 <b>-0.067</b>	-0.003 <b>-0.014</b>	-0.052 <b>0.030</b>	0.057 <b>-0.079</b>
CSE1	0.020 <b>0.022</b>	(0.829) <b>(0.773)</b>	-0.066 <b>0.050</b>	-0.087 <b>0.016</b>	0.063 <b>0.045</b>	0.024 <b>-0.097</b>
CSE2	0.270 <b>0.089</b>	(0.893) <b>(0.908)</b>	0.066 <b>-0.033</b>	-0.063 <b>-0.041</b>	0.117 <b>-0.019</b>	-0.027 <b>-0.039</b>

CSE3	0.012	<b>-0.084</b>	(0.858)	<b>(0.814)</b>	0.112	<b>0.000</b>	-0.122	<b>-0.007</b>	0.085	<b>-0.026</b>	0.000	<b>0.034</b>
CSE4	-0.101	<b>-0.085</b>	(0.897)	<b>(0.887)</b>	0.034	<b>-0.052</b>	-0.029	<b>-0.042</b>	0.023	<b>0.085</b>	-0.034	<b>0.024</b>
CSE5	-0.066	<b>0.061</b>	(0.708)	<b>(0.732)</b>	-0.106	<b>0.008</b>	0.241	<b>0.030</b>	-0.242	<b>-0.046</b>	0.014	<b>0.002</b>
CSE6	-0.146	<b>0.000</b>	(0.884)	<b>(0.883)</b>	-0.064	<b>0.035</b>	0.100	<b>0.052</b>	-0.089	<b>-0.043</b>	0.029	<b>0.068</b>
TE2	-0.034	<b>0.051</b>	0.055	<b>-0.174</b>	(0.835)	<b>(0.808)</b>	0.104	<b>0.252</b>	0.060	<b>-0.003</b>	-0.151	<b>-0.176</b>
TE4	0.108	<b>-0.075</b>	-0.013	<b>-0.028</b>	(0.878)	<b>(0.887)</b>	0.039	<b>0.016</b>	0.009	<b>-0.014</b>	0.075	<b>0.111</b>
TE5	-0.147	<b>0.046</b>	0.020	<b>0.195</b>	(0.820)	<b>(0.764)</b>	-0.149	<b>-0.287</b>	-0.068	<b>0.010</b>	0.073	<b>0.048</b>
TE6	0.027	<b>0.042</b>	0.040	<b>0.054</b>	(0.860)	<b>(0.853)</b>	-0.150	<b>-0.198</b>	0.012	<b>0.038</b>	0.029	<b>0.115</b>
TE7	0.040	<b>-0.059</b>	-0.113	<b>-0.039</b>	(0.754)	<b>(0.765)</b>	0.173	<b>0.222</b>	-0.017	<b>-0.033</b>	-0.032	<b>-0.118</b>
CA1	0.125	<b>0.225</b>	0.047	<b>0.075</b>	0.081	<b>0.002</b>	(0.768)	<b>(0.740)</b>	0.104	<b>-0.125</b>	-0.355	<b>0.005</b>
CA2	-0.027	<b>-0.091</b>	0.032	<b>0.066</b>	-0.031	<b>-0.050</b>	(0.777)	<b>(0.775)</b>	0.063	<b>0.137</b>	0.311	<b>0.098</b>
CA3	-0.066	<b>-0.021</b>	0.057	<b>-0.012</b>	-0.012	<b>0.007</b>	(0.958)	<b>(0.952)</b>	0.007	<b>-0.018</b>	0.016	<b>-0.024</b>
CA4	-0.016	<b>-0.101</b>	-0.149	<b>-0.127</b>	-0.034	<b>0.041</b>	(0.774)	<b>(0.752)</b>	-0.175	<b>0.005</b>	0.020	<b>-0.075</b>
CB2	0.051	<b>0.125</b>	0.044	<b>-0.048</b>	0.106	<b>0.072</b>	0.028	<b>0.075</b>	(0.895)	<b>(0.894)</b>	0.021	<b>-0.024</b>
CB3	-0.124	<b>0.028</b>	0.235	<b>-0.019</b>	0.054	<b>0.043</b>	0.009	<b>0.153</b>	(0.694)	<b>(0.718)</b>	0.208	<b>-0.007</b>
CB4	0.084	<b>-0.031</b>	-0.145	<b>0.063</b>	-0.016	<b>0.000</b>	-0.026	<b>-0.056</b>	(0.874)	<b>(0.874)</b>	-0.131	<b>-0.052</b>
CB5	0.051	<b>0.000</b>	-0.054	<b>-0.060</b>	0.018	<b>-0.033</b>	-0.012	<b>-0.036</b>	(0.909)	<b>(0.880)</b>	-0.081	<b>0.051</b>
CB6	-0.106	<b>-0.140</b>	-0.036	<b>0.073</b>	-0.179	<b>-0.090</b>	0.003	<b>-0.131</b>	(0.752)	<b>(0.742)</b>	0.034	<b>0.037</b>
SI1	0.019	<b>-0.011</b>	-0.010	<b>0.058</b>	0.055	<b>0.047</b>	0.158	<b>-0.074</b>	-0.044	<b>0.023</b>	(0.830)	<b>(0.836)</b>
SI2	-0.040	<b>0.004</b>	0.085	<b>-0.024</b>	-0.085	<b>0.009</b>	-0.124	<b>0.072</b>	0.045	<b>-0.009</b>	(0.862)	<b>(0.892)</b>
SI3	-0.092	<b>-0.151</b>	-0.127	<b>-0.055</b>	0.072	<b>0.012</b>	0.215	<b>-0.034</b>	-0.129	<b>-0.032</b>	(0.758)	<b>(0.775)</b>
SI4	0.123	<b>0.171</b>	0.043	<b>0.022</b>	-0.039	<b>-0.079</b>	-0.261	<b>0.034</b>	0.134	<b>0.019</b>	(0.715)	<b>(0.719)</b>

Note: Non-mathematics in bold. SLCU= Computer as a learning tool, TTCU= Computer as a teaching tool, SKCU= Computer for basic skills, CU = Computer use, CSE = Computer self-efficacy, TE = Teacher efficacy, CA = Computer attitude, CB = Constructivist belief, and SI = Social influence. Loadings are shown within parentheses; the loadings are un-rotated and cross-loadings are oblique-rotated; all loadings are significant at  $p < .001$  level.

After the assessment of convergent validity, discriminant validity was assessed. The goal of verifying discriminant validity was to test whether the LVs in this study differed from each other distinctly (Fornell & Larcker, 1981). Discriminant validity was tested by comparing the inter-construct correlations with the square roots of their respective average variance extracted (AVE). The square roots of AVEs for each LV must be greater than any correlation relating to each LV (Barroso et al., 2010; Fornell & Larcker, 1981; Henseler et al., 2009) in order to signify acceptable level of discriminant validity.

Table 3 shows correlations between LVs and square roots of AVEs for the mathematics and non-mathematics teacher subsamples. The square roots of AVEs for each LV are shown in the diagonal and within parentheses. From Table 3, all the square roots of AVEs are greater than the magnitudes (that is, size neglecting the sign, + or -) of any correlation relating to each LV. These results implied that this study had a satisfactory level of discriminant validity of the LVs and therefore the results can be trusted to give unbiased estimates of sample statistics.

**Table 3. Correlations among LVs and square roots of AVEs for the two teacher subsamples**

	CU	CSE	TE	CA	CB	SI
CU	(0.795) <b>(0.825)</b>					
CSE	0.475 <b>0.409</b>	(0.847) <b>(0.835)</b>				
TE	-0.117 <b>-0.010</b>	0.059 <b>0.093</b>	(0.830) <b>(0.817)</b>			
CA	0.203 <b>0.285</b>	0.415 <b>0.360</b>	0.058 <b>0.316</b>	(0.823) <b>(0.809)</b>		
CB	-0.109 <b>0.251</b>	0.085 <b>0.201</b>	0.196 <b>0.218</b>	0.277 <b>0.306</b>	(0.829) <b>(0.825)</b>	
SI	0.166 <b>0.280</b>	0.167 <b>0.139</b>	0.072 <b>0.121</b>	0.433 <b>0.431</b>	0.371 <b>0.228</b>	(0.793) <b>(0.808)</b>

Note: Non-mathematics in bold. CU= Computer use, CSE = Computer self-efficacy, TE = Teacher efficacy, CA = Computer attitude, CB = Constructivist belief, and SI = Social influence. AVE= Average variance extracted. Square roots of AVEs are shown in the diagonal within parentheses. Correlations are given in off-diagonals

5.2.3. Reliability Assessment

The assessment of measurement model reliability is typically assessed using composite reliability or Cronbach alpha based tests. For either composite reliability or Cronbach alpha, a value of 0.7 and above has been use for practical purposes (Santos, 1999). Cronbach alpha provides an estimate of the indicator inter-correlations (Henseler et al., 2009). Table 4 shows that all LVs in this study have Cronbach alpha values above the threshold for Cronbach alpha for the mathematics and non-mathematics teacher subsamples. However, Cronbach alpha underestimates reliability because it assumes that all indicator loadings are equal (Henseler et al., 2009). Composite reliability provides another (and better) means for assessing measurement model reliability; and it takes into account the differences in indicator loadings. Therefore, composite reliability estimates the *true* reliability of LVs. Table 4 indicates that all the composite reliabilities for LVs exceeded the threshold value.

Another measure of reliability is the AVE (Fornell & Larcker, 1981). This measure quantifies the amount of variance that a construct (LV) captures from its manifest variables or indicators relative to the amount due to measurement error. AVE should be greater than 0.50 (Fornell & Larcker, 1981). This means that 50% or more of the indicator variance should be accounted for (Henseler et al., 2009). Table 4 for the two teacher subsamples; indicates that all AVEs are greater than 0.50 for all LVs suggesting sufficient reliability.

A full collinearity test was run to examine if there was multicollinearity among all the independent and the dependent variables (LVs). This test found that the variance inflation factor (VIF) values for all LVs were less than value of 5 (Kock, 2013a). This implies that the collinearity between the study variables can be ruled out as a significant source of bias in the results.

**Table 4 Latent variable Reliability Estimates for the two teacher subsamples**

	CU	CSE	TE	CA	CB	SI
Composite Reliability	0.838 <b>0.864</b>	0.938 <b>0.932</b>	0.917 <b>0.909</b>	0.893 <b>0.883</b>	0.916 <b>0.914</b>	0.871 <b>0.882</b>
Cronbach Alpha, $\alpha$	0.710 <b>0.764</b>	0.920 <b>0.912</b>	0.887 <b>0.874</b>	0.837 <b>0.819</b>	0.883 <b>0.880</b>	0.801 <b>0.820</b>
AVE	0.633 <b>0.680</b>	0.718 <b>0.698</b>	0.690 <b>0.667</b>	0.677 <b>0.655</b>	0.688 <b>0.681</b>	0.629 <b>0.653</b>
Full Collinearity VIF	1.790 <b>1.481</b>	1.851 <b>1.662</b>	1.216 <b>1.212</b>	2.016 <b>2.038</b>	1.452 <b>1.341</b>	1.662 <b>1.383</b>

Note: Non-mathematics in **bold**. CU = Computer use, CSE = Computer self-efficacy, TE = Teacher efficacy, CA = Computer attitude, CB = Constructivist belief, and SI = Social influence. AVE = average variance extracted, VIF = variance inflation factor; VIF < 5 suggests non-collinearity.

5.3. Measurement Model Differences

To assess measurement model invariance, measurement model differences between the mathematics and non-mathematics teacher subsamples were computed using MS Excel spreadsheet software (Kock, 2013b, 2013c). Table 5 shows the measurement model differences by reporting the significance (p value) of each pair of corresponding indicator weights for the two teacher subsamples. The values of T and p are computed by WarpPLS 4.0 (Kock, 2013b). This “multigroup” procedure makes use of the indicator weights (coefficients), standard errors, and sample sizes of the two teacher subsamples. WarpPLS 4.0 calculates the standard errors by default using the “stable” resampling technique (Kock, 2013a).

From Table 5, it is observed that there are no statistically significant differences in all the indicator weights ( $p > .05$ ). Therefore, these findings indicated that there was measurement invariance. This was construed to mean that the respondents across the two teacher subsamples interpreted both the item (indicator) and the underlying latent construct in the same way (Van de Schoot, Lugtig & Hox, 2012). Overall, the proposed measurement models met most of the required thresholds for convergent validity, discriminant validity, reliability, collinearity, and measurement invariance. These model assessment results demonstrate that the research model met acceptable data validation criteria (Fornell & Larcker, 1981; Gefen & Straub, 2005). Therefore, data were deemed fit and reasonable to be used for hypotheses test proposed for this study.

**Table 5. Measurement Model Differences between the Two Teacher Subsamples**

	Mathematics		Non-mathematics		T	P
	Weight	SE	Weight	SE		
SLCU	0.422	0.070	0.415	0.051	0.0793	.4684
TTCU	0.409	0.070	0.382	0.051	0.3058	.3800
SKCU	0.426	0.070	0.414	0.051	0.1359	.4460
CSE1	0.192	0.070	0.185	0.051	0.0793	.4684
CSE2	0.207	0.070	0.217	0.051	-0.1133	.4549
CSE3	0.199	0.070	0.195	0.051	0.0453	.4819
CSE4	0.208	0.070	0.212	0.051	-0.0453	.4819
CSE5	0.164	0.070	0.175	0.051	-0.1246	.4503
CSE6	0.205	0.070	0.211	0.051	-0.0680	.4729
TE2	0.242	0.070	0.242	0.051	0.0000	.5000



---

TE4	0.255	0.070	0.266	0.051	-0.1246	.4505
TE5	0.238	0.070	0.229	0.051	0.1019	.4594
TE6	0.249	0.070	0.256	0.051	-0.0793	.4684
TE7	0.219	0.070	0.229	0.051	-0.1133	.4549
CA1	0.283	0.070	0.282	0.051	0.0113	.4955
CA2	0.287	0.070	0.296	0.051	-0.1019	.4594
CA3	0.353	0.070	0.363	0.051	-0.1133	.4549
CA4	0.286	0.070	0.287	0.051	-0.0113	.4955
CB2	0.260	0.070	0.263	0.051	-0.0340	.4865
CB3	0.202	0.070	0.211	0.051	-0.1019	.4594
CB4	0.254	0.070	0.257	0.051	-0.0340	.4865
CB5	0.264	0.070	0.259	0.051	0.0566	.4774
CB6	0.219	0.070	0.218	0.051	0.0113	.4955
SI1	0.330	0.070	0.320	0.051	0.1133	.4549
SI2	0.342	0.070	0.341	0.051	0.0113	.4955
SI3	0.301	0.070	0.297	0.051	0.0453	.4819
SI4	0.284	0.070	0.275	0.051	0.1019	.4594

---

Note: SLCU = computer as a learning tool, TTCU = computer as a teaching tool, SKCU = computer for basic skills, CSE = computer self-efficacy, TE = teacher efficacy, CA = computer attitude, CB = constructivist belief, SI = social influence; Weight = indicator weight. SE = standard error of indicator weight; T = T statistic; p = P-value for the T statistic, one-tailed test; SE are generated through bootstrapping stable method (Kock, 2013a)

#### 5.4. Structural Model Assessment

The inner model specified the relationships between the variables of the study (Hair, Sarstedt, Ringle & Mena, 2012; Henseler et al., 2009). As mentioned earlier, the basic PLS design assumes recursive or a unidirectional inner model that is subject to predictor specification, which constitutes a causal chain system (that is, with uncorrelated residuals and without correlations between the residual term

of endogenous LV and its explanatory LVs) (Barroso et al., 2010; Henseler et al., 2009). In this study, teacher efficacy, social influence and constructivist belief were considered as exogenous while computer self-efficacy, computer attitude and computer use were modeled as endogenous.

The structural model is assessed through several measures (fit indices) that can be calculated by WarpPLS 4.0 (Kock, 2013a). These measures are: (a) Average path coefficient (APC), Average R-squared (ARS) and Average adjusted R-squared (AARS). The statistical significance of these three indices should be significant at least at the  $p < .05$  level and (b) Average block variance inflation factor (AVIF) and Average full collinearity VIF (AFVIF), acceptable if  $\leq 5$ ; Tenenhaus GoF: small  $\leq 0.1$ , medium  $\geq 0.25$  and Large  $\geq 0.36$ ; Sympson’s paradox ratio (SPR), acceptable if  $\geq 0.7$ ; R-squared contribution ratio (RSCR), acceptable if  $\geq 0.9$ ; Statistical suppression ratio (SSR), acceptable if  $\geq 0.7$ ; and Nonlinear bivariate causality direction ratio (NLBCDR), acceptable if  $\geq 0.7$ . Table 6 shows these fit indices. This study met all the required criteria for structural model fit.

**Table 6. Model Fit Indices for the Two Teacher Subsamples**

Index	Mathematics	Non-Mathematics
APC	0.124*	0.119**
ARS	0.271***	0.283***
AARS	0.222***	0.262***
AVIF	1.556	1.577
AFVIF	1.653	1.442
GoF	0.445	0.451
SPR	0.769	0.885
RSCR	0.911	0.951
SSR	0.962	0.962
NLBCDR	0.885	0.846

Note: \*\*\*  $p < .001$ , \*\*  $p < .01$ , \*  $p < .05$ ; APC = Average path coefficient, ARS = Average R-squared, AARS = Average adjusted R-squared, AVIF = Average block variance inflation factor, AFVIF = Average full collinearity VIF, Tenenhaus GoF, SPR = Sympson’s paradox ratio, RSCR = R-squared contribution ratio, SSR = Statistical suppression ratio, NLBCDR = Nonlinear bivariate causality direction ratio.

To test the hypotheses, the main hypotheses HA1-5 were further broken down into specific hypotheses based on each postulated moderator (gender, age and computer experience). Table 7 indicates PLS-SEM analysis of these hypothesized relationships:

1. Hypotheses HA<sub>1.1</sub>, HA<sub>3.2</sub>, HA<sub>3.3</sub>, HA<sub>4.1</sub> and HA<sub>5.2</sub> were not supported for the two teacher subsamples.
2. Hypotheses HA<sub>2.1</sub> and HA<sub>2.2</sub> are supported for both teacher subsamples.
3. Hypotheses HA<sub>1.2</sub>, HA<sub>3.1</sub> and HA<sub>5.1</sub> are supported for mathematics teacher subsample only.
4. Hypothesis HA<sub>4.2</sub> is supported for non-mathematics teacher subsample only.
5. Hypothesis HA<sub>1.3</sub> was significant *but inconsistent* with the stipulated direction.

**Table 7. Hypotheses Test Based on the Results of the Two Teacher Subsamples**

Hypothesis	Beta	
	Math	Non-math
HA <sub>1.1</sub> : Mathematics teacher's gender moderates the positive relationship between teacher's computer self-efficacy and computer use.	0.111 <sup>NS</sup> (0.049)	0.029 <sup>NS</sup> (0.009)
HA <sub>1.2</sub> : Mathematics teacher's age moderates the positive relationship between teacher's computer self-efficacy and computer use.	0.128* (0.032)	0.080 <sup>NS</sup> (0.021)
HA <sub>1.3</sub> : Mathematics teacher's computer experience moderates the positive relationship between teacher's computer self-efficacy and computer use.	0.011 <sup>NS</sup> (0.003)	-0.099* (0.027)
HA <sub>2.1</sub> : Mathematics teacher's gender moderates the negative relationship between teacher's general efficacy and computer use.	0.192** (0.017)	0.107* (0.015)
HA <sub>2.2</sub> : Mathematics teacher's age moderates the negative relationship between teacher's general efficacy and computer use.	0.170** (0.038)	-0.094* (0.013)
HA <sub>3.1</sub> : Mathematics teacher's gender moderates the positive relationship between teacher's computer attitude and computer use.	0.129* (0.033)	0.079 <sup>NS</sup> (0.009)
HA <sub>3.2</sub> : Mathematics teacher's age moderates the positive relationship between teacher's computer attitude and computer use.	-0.023 <sup>NS</sup> (0.004)	0.052 <sup>NS</sup> (0.007)
HA <sub>3.3</sub> : Mathematics teacher's computer experience moderates the positive relationship between teacher's computer attitude and computer use.	-0.059 <sup>NS</sup> (0.005)	0.037 <sup>NS</sup> (0.006)

<b>HA<sub>4.1</sub>:</b> Mathematics teacher's gender moderates the positive relationship between teacher's social influence and computer use.	-0.013 <sup>NS</sup> (0.002)	0.025 <sup>NS</sup> (0.003)
<b>HA<sub>4.2</sub>:</b> Mathematics teacher's age moderates the positive relationship between teacher's social influence and computer use.	0.097 <sup>NS</sup> (0.018)	0.114* (0.003)
<b>HA<sub>5.1</sub>:</b> Mathematics teacher's gender moderates the positive relationship between teacher's constructivist belief and computer use	-0.183** (0.033)	-0.061 <sup>NS</sup> (0.001)
<b>HA<sub>5.2</sub>:</b> Mathematics teacher's age moderates the positive relationship between teacher's constructivist belief and computer use.	0.054 <sup>NS</sup> (0.006)	0.064 <sup>NS</sup> (0.006)

Note. Beta = beta or path coefficient; <sup>a</sup> significant but opposite direction from hypothesized one (that is, negative rather than positive); \* $p < .05$ , \*\*  $p < .01$ , NS = not significant.  $f^2$  in parenthesis.

### 5.5 Structural Model Differences

Table 8 shows the structural model equivalence by reporting the significance of differences in the path coefficients between the mathematics and non-mathematics teacher subsamples. Four paths showed statistically significant differences, namely two direct paths (Constructivist belief → Computer Use and Computer Experience → Computer Use), one moderated path (Age by Teacher Efficacy → Computer Use) and one mediated path (Constructivist belief → Computer Self-Efficacy → Computer Use). Therefore these paths are moderated by subject discipline, that is, these hypothesized relationships vary according to respondent's subject discipline or specialization (mathematics or non-mathematics).

From the observed differences, subject specialization moderates the relationship between constructivist belief and computer use such that mathematics teachers depict negative relationship while non-mathematics teachers depict positive relationship. The relationship between computer experience and computer use is more positive for the non-mathematics teachers than the mathematics teacher subsample. There appears to be a significant three-way (age by subject specialization by teacher efficacy) effect on computer use. Finally, the mediated effect (by computer self-efficacy) of constructivist belief on computer use is moderated by subject specialization, indicating a moderated-mediation effect on computer use. In general, the majority of the hypothesized associations were consistent across the two teacher subsamples. This is because no statistically significant ( $p > .05$ ) differences were observed in the beta coefficients estimated based on data from the two teacher subsamples.

**Table 8. Structural Model Differences between the Two Teacher Subsamples**

Path	Beta		SE		T	P
	Math	Non-Math	Math	Non-math		
CSE → CU	0.351***	0.282***	0.070	0.051	0.782	.218
TE → CU	-0.144*	-0.027	0.070	0.051	-1.325	.093
CA → CU	0.062	0.087*	0.070	0.051	-0.283	.389
CB → CU	-0.092	0.096*	0.070	0.051	-2.129	.017
SI → CU	0.040	0.105*	0.070	0.051	-0.736	.231
GND → CU	0.042	-0.020	0.070	0.051	0.702	.242
AGE → CU	-0.017	-0.129**	0.070	0.051	1.269	.103
CEXP → CU	0.144*	0.291***	0.070	0.051	-1.665	.048
GND X CSE → CU	0.111	0.029	0.070	0.051	0.929	.177
AGE X CSE → CU	0.128*	0.080	0.070	0.051	0.544	.294
CEXP x CSE → CU	0.011	-0.099*	0.070	0.051	1.246	.107
GND X TE → CU	0.192**	0.107*	0.070	0.051	0.963	.168
AGE X TE → CU	0.170**	-0.094*	0.070	0.051	2.990	.002
GND X CA → CU	0.129*	0.079	0.070	0.051	0.566	.286
AGE X CA → CU	-0.023	0.052	0.070	0.051	-0.850	.198
CEXP x CA → CU	-0.059	0.037	0.070	0.051	-1.087	.139
GND X SI → CU	-0.013	0.025	0.070	0.051	-0.430	.334
AGE X SI → CU	0.097	0.114*	0.070	0.051	-0.193	.424
GND X CB → CU	-0.183**	-0.061	0.070	0.051	-1.382	.084
AGE X CB → CU	0.054	0.064	0.070	0.051	-0.113	.455
TE → CSE→ CU	0.041	0.008	0.049	0.036	0.531	.298
CA → CSE→ CU	0.160***	0.086**	0.049	0.036	1.190	.117
CB → CSE→ CU	-0.034	0.071***	0.032	0.020	-2.885	.002

---

CB→ CA→ CU	-0.007	0.019	0.011	0.013	-1.277	.101
SI→ CSE→ CU	-0.031	-0.016	0.032	0.016	-0.470	.319
SI→ CA→ CU	-0.024	0.029	0.031	0.020	-1.473	.071

---

Note. CU = computer use, CSE = computer self-efficacy, TE = teacher efficacy, CA = computer attitude, CB = constructivist belief, SI = social influence, GND = gender and CEXP = computer experience; SE = standard errors, T = t values,  $p$  = p-values; \*\*\* $p$  < .001, \*\* $p$  < .01, \* $p$  < .05

## 6. DISCUSSIONS

### 6.1. Relationship between Computer Self-efficacy and Computer Use

This study found a significant direct positive relationship between computer self-efficacy and computer use for both the teacher subsamples. This finding is congruent to Player-Koro's (2012) who concluded that teachers judging themselves to be capable of using ICT in used ICT in their classrooms. Similarly, AL-Ruz and Khasawneh (2011) found that technology self-efficacy was the most important factor with the highest direct effect on technology integration. Similar results have led to the same conclusion that computer self-efficacy has a significant positive relationship with computer use for both elementary and secondary school teachers (Al Dafaiei et al., 2013; Deryakulu et al., 2009; Sang et al., 2010). Contrary to this finding, Kumar et al. (2008) found a non-significant linear relationship between computer self-efficacy and the actual use of computers.

The effect of computer self-efficacy on computer use was postulated to be moderated by the teacher demographics (gender, age) and computer experience. Investigating the moderating effect of gender, age and computer experience on the relationship between computer self-efficacy and computer use, the following findings emerged. Gender did not moderate the relationship between computer self-efficacy and computer use for both teacher subsamples. This finding is dissimilar to the claim that there is significant gender differences in perceptions of general computer self-efficacy (Bao et al., 2013).

Age significantly moderated the relationship between computer self-efficacy and computer use for the mathematics teacher subsample such that older mathematics teachers seem to demonstrate increasing computer use with increasing computer self-efficacy more strongly than their younger counterparts. Similarly, computer experience significantly moderated the relationship between computer self-efficacy and computer use for the non-mathematics teachers subsample, this relationship being salient for non-mathematics teachers with longer computer experience (experts) than their counterparts with shorter computer experience (novices). In general, non-mathematics teacher's prior exposure to computers has a strong impact on computer use compared to mathematics teachers.

### 6.2. Relationship between Teacher Efficacy and Computer Use

This study found a significant negative relationship between teacher efficacy and computer use for mathematics teacher subsample and non-significant for the non-mathematics teachers. The mathematics teachers' finding confirms the hypothesized association, on the basis that mathematics teachers with strong sense of teacher efficacy (teacher efficacy stipulated in this study as a teacher's judgment in being capable to implement classroom tasks not necessarily with computers) will exhibit decreasing computer use. This finding is consistent with the conclusion of Gulbahar and Guven (2008) that teachers' with perceptions of compatibility issues of ICT with their current teaching practices were not as positive in computer use, although this assertion negates the findings from non-mathematics teachers.

One possible explanation for this significant negative relationship between mathematics teachers efficacy and computer use is that of "resistance to change" (Bingimlas, 2009; Blin & Munro, 2008; Hoy, 2000). Mathematics teachers with strong efficacy tend to resist changes that are expected to be brought about by the inclusion of computers to their classroom instructional practices. Anything novel that is bound to change the status quo of practicing mathematics teachers is not willingly accepted. Mathematics teachers who have had an established tradition(s) of doing things develop a form of inertia, a tendency to naturally and spontaneously resist change even with perceived benefits; but not at the expense of their comfort in doing what they believe to do effectively. Teacher classroom practices (such as classroom instruction, management of instructional resources, discipline and control of learners, learner assessment and social interactions) will considerably experience new sets of principles in the presence of computers. Therefore, established mathematics teacher efficacy in these practices is not necessarily transferable to or replicable in the new classroom reality with computers, hence bringing new challenges that result to inefficient computer use.

Teacher efficacy was postulated to have both direct (negative) and indirect effect on computer use through computer self-efficacy. However, computer self-efficacy did not significantly mediate the effect of teacher efficacy on computer use. This finding implies that teacher efficacy has a direct effect (negative) on computer use for mathematics teacher subsample. Therefore, computer self-efficacy does not provide the mechanism through which teacher efficacy influence computer use, although there was a positive (non-significant) relationship between computer self-efficacy and teacher efficacy, suggesting a possible inconsistent mediation (Refer for more details on mediation; MacKinnon, Krull & Lockwood, 2000; MacKinnon, Cheong & Pirlott, 2012).

Investigating the moderating effect of gender and age on the relationship between teacher efficacy and computer use revealed that both significantly moderated the relationship between teacher efficacy and computer use for both teacher subsamples. For instance, the negative relationship between teacher efficacy and computer use depends on gender of the mathematics teacher. Female teachers in both teacher subsamples demonstrated strong negative relationship between weak efficacy and computer use, that is, they are more resistant to change resulting to low computer use. This observation was more salient when teachers possess weak to moderate teacher efficacy.

Age significantly moderated the relationship between teacher efficacy and computer use for both teacher subsamples. This implies that the negative relationship between teacher efficacy and computer use depends on the age of the respondent. Younger teachers who are less efficacious generally exhibit strong negative relationship than older teachers; younger teachers seem to have a threshold level of teacher efficacy where they begin to exhibit increasing computer use. Older teachers with strong sense of teacher efficacy exhibit decreasing use of computers for instruction, that is, they exhibit high resistance to change. Hoy (2000) found that novice teachers completing their first year of teaching who were more efficacious were more satisfied in teaching, exuded more positive reaction to teaching, and experienced less stress. Teacher efficacy can be associated with experience in teaching, that is, vicarious experience. This confirms the argument that experienced teachers are less ready or unlikely to integrate technology into their regular classroom instruction (Baek et al., 2008).

### **6.3 Relationship between Computer attitude and Computer Use**

This study found a significant total effect of computer attitude on computer use for non-mathematics teacher subsample and non-significant for mathematics teachers. The findings of the two teacher subsamples are opposed to each other. The non-mathematics teachers finding corroborates Player-Koro's (2012) claim that attitudes towards the usefulness of ICT for teaching and learning has a positive relation to teacher's use of ICT. Likewise, other studies have established that attitudes are significant positive predictors of computer use and other ICT related programs (Al Dafaiei et al., 2013; Kumar et al., 2008; Rastogi & Malhotra, 2013; Shin, Han & Kim, 2014; Wozney et al., 2006). Buckenmeyer (2008) asserted that teacher's attitude towards ICT was consistently the strongest predictor of usage. These reported findings are contradictory to the mathematics teachers finding. Additionally, Gulbahar and Guven (2008) found strong positive correlation between teachers' attitudes toward ICT in education and their perceptions of the advantage of the use of computers. The mathematics teacher finding supports the studies that found non-significant relationship between positive perception (that is, attitude) and ICT use (Mulwa & Kyalo, 2013; Rahim & Yadollali, 2011). One mechanism through which computer attitude exerted influence on computer use was by the mediating effect of computer self-efficacy. This study established that computer self-efficacy completely mediated the effect of computer attitude on computer use for both teacher subsamples (mediated effect of computer attitude was statistically significant and the direct effect was not, see MacKinnon et al, 2012, p. 318, for interpretation of mediation). This finding supports Al Dafaiei et al. (2013) that self-efficacy fully mediates the relationship between attitudes and the level of using instructional computer technology.

The moderating effect of gender, age and computer experience on the relationship between computer attitude and computer use revealed the following: First, gender significantly moderated the relationship between computer attitude and computer use for mathematics teacher subsample. Male mathematics respondents portrayed strong positive relationship between computer use and computer



attitude than their female counterparts. Age and computer experience did not moderate the relationship between computer attitude and computer use for the two teacher subsamples. In addition, it is worthwhile to note that there was a significant positive and direct effect of computer attitude on computer use for the non-mathematics teacher subsample that was not moderated by the three proposed moderators (gender, age and computer experience). Therefore, computer attitude was a strong direct predictor of computer use for the non-mathematics teacher subsample which confirms Buckenmeyer's (2008) assertion.

#### **6.4. Relationship between Social Influence and Computer Use**

This study found a significant positive relationship between social influence and computer use for the non-mathematics teacher subsample (significant total and direct effects) while the effect is non-significant for mathematics teachers. The non-mathematics teachers finding is congruent to Marcinkiewicz's (1994) claim that social influence correlated with computer use, while being opposed to the findings of mathematics teachers.

The finding of Kumar et al. (2008) of non-significant relationship between social influence and actual computer use corroborates the mathematics teachers finding, though contrary to non-mathematics teacher finding. Against the postulate of Theory of Reasoned Action, Ma et al. (2005) established that social influence did not have significant effect on teacher intention to use computer technology.

In this study, social influence was postulated to have both direct effect and indirect effects (through computer self-efficacy and computer attitude) on computer use. However, computer self-efficacy and computer attitude did not mediate the effect of social influence on computer use for both teacher subsamples.

Investigating the moderating effect of gender and age on the relationship between social influence and computer use revealed the following findings: Gender did not moderate the relationship between social influence and computer use for both teacher subsamples. Age significantly moderated the relationship between social influence and computer use for non-mathematics teacher subsample only. Younger non-mathematics teachers showed high computer use level than their older counterparts with increasing social influence. This finding can be attributed to the fact that younger non-mathematics teachers still value the opinions of significant others in terms of positive response to their practice more than their older counterparts. Younger non-mathematics teachers seem to be conformists (still in the process of developing an identity as a regular teacher hence follow "others") while older non-mathematics teachers (have already developed their identities in their social settings) may no longer regard the opinions of others to be relevant pertaining to their classroom practices, this is perhaps because they already know quite well what they are supposed to be doing. However, older non-mathematics teachers with very strong social influence had their computer use level

surpass that of their younger colleagues who have very strong social influence. This indicates that in the occasion that older teachers highly regard the opinions of others, their computer use is high.

## 6.5. Relationship between Constructivist Belief and Computer Use

This study found a positive relationship between constructivist belief and computer use for non-mathematics teacher subsample as expected. However, a negative relationship was found for the mathematics teacher subsample, against the predetermined direction.

The finding that indicates a positive relationship between constructivist belief and computer use for non-mathematics teacher subsample is congruent to Chen and Reimer's (2009) claim that teachers' pedagogical beliefs affected teacher practice regarding the specific issue of technology integration in the classroom. However, these pedagogical beliefs (reported by Chen & Reimer's, 2009) were not a primary factor influencing most teachers' decisions on integrating technology into the classroom. This seemingly conflicting conclusion is supported by Liu (2011) on the relations between traditional and constructivist belief and instructional activities who found that teachers who held either teacher-centered (traditional) beliefs or learner-centered (constructivist) beliefs utilized lecture-based activities when using technology. Ideally, it would be expected that traditional belief lead to the use of teacher-centered activities while constructivist belief lead to learner-centered activities. Therefore, the negative relationship between constructivist belief and computer use by mathematics teachers is mainly explained by these inconsistencies.

In spite of the importance attached to constructivist belief and computer use in the classroom (Onasanya, Shehu, Oduwaiye & Shehu, 2010; Sang, Valcke, van Braak, Tondeur & Zhu, 2011), other studies have also established inconsistencies between pedagogical beliefs and teacher practice (Bate, 2010; Chen, 2008). This inconsistency may eventually diminish the ascribed importance of constructivist belief as not necessarily the panacea in the quest for computer integration into pedagogy.

Similarly, inconclusive findings have been echoed (Bingimlas & Hanrahan, 2010; Granger et al., 2002; Lim & Chai, 2008). On a review of literature on the relationship between teacher pedagogical beliefs and their practices, Bingimlas and Hanrahan (2010) gave three general perspectives: beliefs as influential, weakly influential or exhibit a complex relation with teacher practice. This mismatch between pedagogical beliefs and teacher practice can be explained by considering the influence of external or internal factors (Chen, 2008; Handal & Herrington, 2003; Lim & Chai, 2008; Mansour, 2009).

Nonetheless, Wozney et al. (2006) found that teachers who leaned towards learner-centered instructional methods integrated computer technologies more than teachers who preferred teacher-centered methods. Consistent to this finding is the work of Hermans et al. (2008) and Windschitl and Sahl (2002) that teacher pedagogical beliefs are strong predictors of classroom use of computers for

primary school teachers. On the other hand, Khader (2012) found statistically non-significant association between pedagogical beliefs among social studies teachers and their practices.

Constructivist belief was hypothesized to have both direct effect and indirect effects (through computer self-efficacy and computer attitude). However, computer self-efficacy was the only variable that mediated the effect of constructivist belief for the non-mathematics teacher subsample. This implies that computer self-efficacy provides the mechanism through which constructivist belief exert positive influence on pedagogical use of computer. About teacher technology use for classroom practices, teacher optimal beliefs need to be consistent with the theoretical foundations of their practices and also there is need for optimal classroom conditions (Gilakjani, 2012; Khader, 2012).

Investigating the moderating effect of gender and age on the relationship between constructivist belief and computer use revealed that: gender significantly moderated the relationship between constructivist belief and computer use for mathematics teacher subsample. Female mathematics respondents showed stronger negative relationship between constructivist belief and computer use than their male counterparts. Conversely, age did not moderate the relationship between constructivist belief and computer use for the two teacher subsamples. Therefore, the strength of the relationship between constructivist belief and computer use is not affected by age of the secondary school teacher of mathematics or non-mathematics.

## 7. CONCLUSIONS

The Theory of Reasoned Action postulated that attitude towards behaviour and social influence (synonymous to subjective norm) (Venkatesh et al. 2003) jointly determines behavioural intention which in turn influences target behaviour. This study, however, hypothesized that both computer attitude and social influence directly and indirectly influence computer use, based on the reported weaknesses of the behavioural intention construct. Consistent with these claims, this study found that: attitude towards behaviour (computer use) had significant total effects on computer use mediated by computer self-efficacy for mathematics teacher subsample. Gender moderated the effect of computer attitude on computer use for mathematics teachers. Social influence similarly had significant positive total effects on computer use for mathematics teacher subsample. However, neither computer self-efficacy nor computer attitude mediated this effect. Age moderated the effect of social influence on computer use for mathematics teachers.

The Social Cognitive Theory postulates that humans as individuals or groups exercise control over their actions. This control echoes the self-efficacy of teachers as proposed in this study. The two forms of self-efficacy that were studied are computer self-efficacy and teacher general efficacy. Teacher computer self-efficacy undoubtedly had a strong influence on computer use in the classroom. Teacher's judgment on the capability to implement computer-based instructional tasks led up to actual use of computers. Age and computer experience moderated the effect of computer self-efficacy on computer use for mathematics and non-mathematics teachers, respectively. Both gender and age moderated the effect of teacher efficacy on computer use for the two teacher subsamples. This could be attributed to the fact that teacher efficacy once formed is relatively a stable construct

that resists sudden change. As was proposed in this study, stipulated or expected change as a result of infusion of computer-based instructional tasks to teacher practice takes sometime before significant positive effect is observed. The introduction of computers to classroom practice in the Kenyan school context is a recent phenomenon that is yet to significantly impact on the mainly traditional teacher practices that have long been sustained.

Constructivist theory provided an orientation on teacher classroom practices that postulates reciprocal and active construction of knowledge between the student and the teacher. Learners construct knowledge a priori. Constructivist pedagogical belief had significant total effect on computer use for both teacher subsamples. However, this effect was negative for mathematics teachers and positive for non-mathematics teachers – an apparent conflict. Furthermore, gender moderated the negative effect of constructivist pedagogical beliefs for the mathematics teachers only. Teacher constructivist pedagogical beliefs in relation to the unique classroom tasks facilitated by the computer indicated inconsistencies between beliefs and teacher practice. It is appreciated that the relationship between teacher constructivist belief and their practices with respect to classroom computer use is a complex one. Third variables (internal or external factors) come in handy to explain this inconsistent relationship. These variables include pressure to complete the syllabus, lack of customized computer applications, technical support issues, and administrative support.

Computer (or ICT) use for pedagogical practices is an important achievement in the contemporary educational cycles. The results of this study revealed that secondary school teacher reported use of computer reflects a vital progress in bridging the digital gap between teachers (referred to as digital migrants) and their students (referred to as digital natives).

## **8. RECOMMENDATIONS**

Computer self-efficacy is a strong predictor of computer use. This implies that promoting teachers' exposure to computers will increase their confidence to use computers in instruction. It is recommended that schools and the Ministry of Education should ensure teacher exposure to computer use through in-service education and training. Pre-service training and education should also be encouraged. Programs such as continuous professional development, follow ups and mentoring by teacher colleagues come in handy.

Teacher efficacy plays a negative role in the use of computer in the classroom. That is, teachers can resist change, and thus computer integration can suffer a serious setback as a result. It is recommended that a "bottom-up" approach to computer integration be taken into consideration. Teachers must be the first to show acceptance but should not feel like computers are imposed onto their normal way of doing things.

Constructivist pedagogical belief is inconsistent in their influence on computer use for instruction between mathematics and non-mathematics teachers. It is recommended that integration of ICT in

pedagogy should take into account the unique pedagogical beliefs of teachers to increase chances of success

Funding: This study received no specific financial support.

Conflict of interest: The authors declare that there is no conflict of interest.

## REFERENCES

- Abubakar, F.M., & Amhad, H.B. (2013). The moderating effect of technology awareness on the relationship between UTAUT constructs and behavioural intention to use technology: a conceptual paper. *Australian Journal of Business and Management Research*, 3(2), 14 - 23.
- Abukhazam, M., & Lee, A. (2010). Workforce attitude on technology adoption and diffusion. *The Built & Human Environment Review*, 3, 60 - 71.
- Afshari, M., Bakar, K. A., Luan, W. S., Samah, B. A., & Fooi, F. S. (2009). Factors affecting teachers' use of information and communication technology. *International Journal of Instruction*, 2(1), 77 - 104.
- Ajzen, I. (2002). Perceived behavioural control, self-efficacy, locus of control and the Theory of Planned Behavior. *Journal of Applied Social Psychology*, 32(4), 665 - 683. <https://doi.org/10.1111/j.1559.1816.2002.tb00236.x>
- Al Dafaiei, I.M., Ismail, Z., Sansuidin, M.A., & Shakir, F.I. (2013). The mediating effect of self-efficacy towards the relationship between attitudes and level of use towards instructional computer technology in Oman. *International Journal of Asian Social Science*, 3(12), 2382 - 2398.
- Al-Ruz, J.A., & Khasawneh, S. (2011). Jordanian pre-service teachers and technology integration: a human resource development approach. *Educational Technology & Society*, 14(4), 77 - 87.
- Baek, Y., Jung, J., & Kim, B. (2008). What makes teachers use technology in the classroom? Exploring the factors affecting facilitation of technology with a Korean sample. *Computers & Education*, 50, 224-234. <https://doi.org/10.1016/j.compedu.2006.05.002>
- Bagozzi, R.P. (2007). The legacy of the technology acceptance model and a proposal for a paradigm shift. *Journal of the Association for Information Systems*, 8(4), 7, 244-254.
- Bandura, A. (2001). Social cognitive theory: An agentic perspective. *Annual Reviews Psychology*, 52, 1-26.
- Bao, Y., Xiong, T., Hu, Z., & Kibelloh, M. (2013). Exploring gender differences on general and specific computer self-efficacy in mobile learning adoption. *Journal of Educational Computing Research*, 49(1), 111-132
- Barroso, C., Carrion, G.C., & Roldan, J.L. (2010). Applying maximum likelihood and PLS on different sample sizes: Studies on SERVQUAL model and employee behaviour model. In V. Espisito Vinzi, W.W. Chin, J. Henseler, & H. Wang (Eds.), *Handbook of Partial Least Squares* (pp. 427- 447). [https://doi.org/10.1007/978-3-540-32827-8\\_20](https://doi.org/10.1007/978-3-540-32827-8_20)
- Baruch, Y., & Hollton, B.C. (2008). Survey response rate levels and trends in organizational research. *Human Relations*, 61(8), 1139-1160. <https://doi.org/10.1177/0018726708094863>

- Baser, V. G., & Mutlu, N. (2011). Analysing pre-service elementary teachers' pedagogical beliefs. *International Journal on New Trends on Education and Their Implications*, 2(4), 95-101
- Bate, F. (2010). A bridge too far? Explaining teacher's use of ICT in Australian schools. *Australasian Journal of Educational Technology*, 26(7), 1042-1061
- Bingimlas, K. A. (2009). Barriers to the successful integration of ICT in teaching and learning environments: A review of the literature. *Eurasia Journal of Mathematics, Science & Technology Education*, 5(3), 235-245
- Bingimlas, K., & Hanrahan, M. (2010). The relationship between teachers' beliefs and their practice: How the literature can inform science education reformers and researchers. In M. F. Tasar & G. Cakmakci (Eds.), *Contemporary Science Education research: International perspectives* (pp. 415-422). Ankara: Pegem Akademi. Retrieved from [http://www.esera2009.org/books/BOOK3\\_CSER\\_intl\\_pers.pdf](http://www.esera2009.org/books/BOOK3_CSER_intl_pers.pdf)
- Birisci, S., Metin, M., & Karakas, M. (2009). Prospective elementary teachers' attitudes toward computer and internet use: a sample from Turkey. *World Applied Sciences Journal*, 6(10), 1433-1440.
- Blin, F., & Munro, M. (2008). Why hasn't technology disrupted academics' teaching practices? Understanding resistance to change through the lens of activity theory. *Computers & Education*, 50, 475-490.
- Bruce, C.D., & Ross, J.A. (2008). A model of increasing reform implementation and teacher efficiency: teacher peer coaching in Grades 3 and 6 Mathematics. *Canada Journal of Education*, 31(2), 346-370.
- Buckenmeyer, J. (2008). Revisiting teacher adoption of technology: Research implications and recommendations for successful technology integration. *College Teaching Methods & Styles Journal*, 4(6), 7-10.
- Chen, C.-H. (2008). Why do teachers not practice what they believe regarding technology integration? *The Journal of Educational Research*, 102(1), 65-75
- Chen, C.-H., & Reimer, T.C. (2009). Teacher beliefs, contextual factors, and Taiwanese high school teachers' integration of technology into the classroom. *International Journal on Digital Learning Technology*, 1(3), 224-244.
- Compeau, D. R., & Higgins, C. A. (1995). Computer self-efficacy: Development of a measure and initial test. *MIS Quarterly*, 19, 189-211. DOI.10.2307/249688
- Deryakulu, D., Buyukozturk, S., Karadeniz, S., & Olkun, S. (2009). Satisfying and frustrating aspects of ICT teaching: a comparison based on self-efficacy. *International Journal of Human and Social Sciences*, 4 (9), 664-667.
- Diamantopoulos, A., Riefler, P., & Roth, K.P. (2008). Advancing formative measurement models. *Journal of Business Research*, 61, 1203-1218.
- Fabrigar, L.F., MacCallum, R.C., Wegener, D.T., & Strahan, E.J. (1999). Evaluating the use of exploratory factor analysis in psychological research. *Psychological Methods*, 4(3), 272-299.
- Fincham, J.E. (2008). Response rates and responsiveness for surveys, standards, and the Journal. *American Journal of Pharmaceutical Education*, 72(2), 43, 1-3.

- Fornell, C., & Larcker, D.F. (1981). Evaluating structural equation models with unobservable variables and measurement error. *Journal of Marketing Research*, 18(1), 39-50.
- Franke, G.C., Preacher, K.J., & Rigdon, E.E. (2008). Proportional structural effects of formative indicators. *Journal of Business Research*, 61, 1229-1237. <https://doi.org/10.1016/j.jbusres.2008.01.011>
- Gefen, D., & Straub, D. (2005). A practical guide to factorial validity using PLS-GRAPH: tutorial and annotated example. *Communications of the Association for Information Systems*, 16, 91-109.
- Gilakjani, A.P. (2013). Factors contributing to teachers' use of computer technology in the classroom. *Universal Journal of the Education Research*, 1(3), 262-267.
- Goddard, R.D., & Skrla, L. (2006). The influence of school social composition on teachers' collective efficiency beliefs. *Educational Administration Quarterly*, 42 (2), 216-236.
- Goddard, R.D., Hoy, W.K., & Woolfolk Hoy, A. (2004). Collective efficacy beliefs: theoretical development, empirical evidence, and future directions. *Educational Researcher*, 33 (3), 3-13.
- Granger, C.A., Morbey, M.L., Lotherington, H., Owston, R.D., & Wideman, H.H. (2002). Factors contributing to teachers' successful implementation of IT. *Journal of Computer Assisted Learning*, 18(4), 480-488. <https://doi.org/10.1046/j.0266-4909.2002.00259.doc.x>
- Gulbahar, Y., & Guven, I. (2008). A survey on ICT usage and the perceptions of social studies teachers in Turkey. *Education, Technology & Society*, 11(3), 37-51.
- Hair, J.F., Sarstedt, M., Ringle, C.M., & Mena, J.A. (2012). An assessment of the use of partial least squares structural equation modeling in marketing research. *Journal of Academy of Marketing Science*, 40, 414-433. <https://doi.org/10.1007/s1747-011-0261-6>
- Handal, B., & Herrington, A. (2003). Mathematics teachers' beliefs and curriculum reform. *Mathematics Education Research Journal*, 15(1), 59-69.
- Henseler, J., Ringle, C., & Sinkovics, R. (2009). The use of partial least squares path modeling in international marketing. *Advances in International Marketing*, 8(20), 277-319. [https://doi.org/10.1108/51474-7979\(2009\)000002004](https://doi.org/10.1108/51474-7979(2009)000002004)
- Hermans, R., Tondeur, J., van Braak, J., & Valcke, M. (2008). The impact of primary school teachers' educational beliefs on the classroom use of computers. *Computers & Education*, 51, 1499-1509. <https://doi.org/10.1016/j.comedu.2008.02.001>
- Hoy, A.W. (2000, April). Changes in teacher efficacy during the early years of teaching. Paper presented at the annual meeting of the American Educational Research Association, New Orleans, LA.
- Hung, Y.-W., & Hsu, Y.-S. (2007). Examining teachers' CBT use in the classroom: a study in secondary schools in Taiwan. *Educational Technology & Society*, 5(2), 183-206.
- Jarvis, C.B., MacKenzie, S.B., & Podsakoff, P.M. (2003). A critical review of construct indicators and measurement model misspecification in marketing and consumer research. *Journal of Consumer Research*, 30(2), 199-218.
- Jegade, P.O. (2008). ICT attitudinal characteristics and use level of Nigerian teachers. *Issues in Information Science and Information Technology*, 5, 261-266.

- Khader, F.R. (2012). Teachers' pedagogical beliefs and actual classroom practices in social studies instruction. *American International Journal of Contemporary Research*, 2(1), 73-92.
- Kline, R.B. (2012). Assumptions of structural equation modeling. In R. Hoyle (Ed.), *Handbook of Structural Equation Modeling* (pp. 111-125). New York: Guilford Press.
- Kock, N. (2010a). Using second order latent variables in WarpPLS. Retrieved from <http://warppls.blogspot.com/2010/06/using-second-order-latent-variables-in.html>
- Kock, N. (2010b). Using WarpPLS in e-collaboration studies: an overview of five main steps. *International Journal of e-Collaboration*, 6(4), 1-11. <https://doi.org/10.4018/jec.2010100101>
- Kock, N. (2011). Using WarpPLS in e-Collaboration studies: descriptive statistics, settings, and key analysis results. *International Journal of e-Collaboration*, 7(2), 1-118. <https://doi.org/10.4018/jec.2011040101>
- Kock, N. (2013a). WarpPLS 4.0 user manual. Laredo, TX: Scriptwarp Systems.
- Kock, N. (2013b). Excel spreadsheet for Sobel Mediation Analysis [Software]. Retrieved from [http://www.scriptwarp.com/warppls/rscs/Kock\\_2013\\_MediationSobel.xls](http://www.scriptwarp.com/warppls/rscs/Kock_2013_MediationSobel.xls)
- Kock, N. (2013c). Excel spreadsheet for multigroup analysis [Software]. Retrieved from [http://www.scriptwarp.com/warppls/rscs/Kock\\_2013\\_MultiGroup.xls](http://www.scriptwarp.com/warppls/rscs/Kock_2013_MultiGroup.xls)
- Kumar, N., Rose, R.C., & D'Silva, J.L. (2008). Teachers' readiness to use technology in the classroom: an empirical study. *European Journal of Scientific Research*, 21(4), 603-616.
- Kurgat, J. S. (2011). Towards the integrated e-learning approach in Kenyan secondary schools: The perception of Business Studies teachers and students in selected E-schools (unpublished Doctoral thesis). Moi University, Eldoret.
- Kutluca, T. (2011). A study on computer usage and attitudes toward computers of prospective preschool teachers. *International Journal on New Trends in Education and Their Implications*, 2 (1), 1-17.
- Leon, J. (2012). Create and use second order latent variables in WarpPLS [video file]. Retrieved from <http://youtube.be/bk06YoRk8Zg>
- Lim, C. P., & Chai, C.S. (2008). Teachers' pedagogical beliefs and their planning and conduct of computer-mediated classroom lessons. *British Journal of Educational Technology*, 39(5), 807-828. <https://doi.org/10.1111/j.1467-8535.2007.00774.x>
- Lim, C. P., & Chan, B. C. (2007). MicroLESSONS in teacher education: examining pre-service teachers' pedagogical beliefs. *Computers & Education*, 48, 474-494.
- Liu, S.-H. (2011). Factors related to pedagogical beliefs of teachers and technology integration. *Computers & Education*, 56, 1012-1022. <https://doi.org/10.1016/j.compedu.2010.12001>
- MacKinnon, D.P., Cheong, J., & Pirlott, A. G. (2012). Statistical mediation analysis. In Cooper, H. (Ed.), *APA Handbook of Research Methods in Psychology* (pp. 313-331), Vol. 2. <https://doi.org/10.1037/13620-018>
- MacKinnon, D.P., Krull, J.L., & Lockwood, C.M. (2000). Equivalence of mediation, confounding and suppression effect. *Prevention Science*, 1(4), 173-181.
- Mansour, N. (2009). Science teachers' beliefs and practices: issues, implications and research agenda. *International Journal of Environment & Science Education*, 4 (1), 25 – 48.



- Marcinkiewicz, H. R. (1994, February). Subjective norms predicting computer use. In proceedings of selected research and presentations, National Convention of the Association for Educational Communications and Technology. Nashville, TN.
- Markauskaite, L. (2007). Exploring the structure of trainee teachers' ICT literacy the main components of, and relationships between, general cognitive and technical capabilities. *Educational Technology Research and Development*, 55 (6), 547 – 572.
- Ministry of Education, MoE (2006). National information and communication (ICT) strategy for education and training. Retrieved from <http://www.education.go.ke/Documents>
- Ministry of Education, Science and Technology, MoEST (2005). A policy framework for education, training and research. Sessional paper No. 1 of 2005. Republic of Kenya.
- Ministry of Information and Communications, MoIC (2006). National information and communication technology (ICT) policy. Retrieved from <http://www.information.go.ke>
- Mulwa, A.S., & Kyalo, D.N. (2013). The influence of principals', teachers' and students' attitude on readiness to adopt e-learning in secondary schools in Kitui District, Kenya. *European Scientific Journal*, 9(5), 183-202.
- Mwei, P. K., Too, J. K., & Okioma, M. L. (2019). Typologies and Multidimensional nature of computer use for classroom instruction in secondary education. *International Journal of Educational Technology and Learning*, 6(1), 1-10. <https://doi.org/10.20448/2003.61.1.10>
- Mwei, P.K. (2020). Teachers' perception of factors affecting integration of Information and Communication Technology for instructional purposes in secondary schools in Kenya. *International Journal of Educational Technology and Learning*, 8(1), 25-37. <https://doi.org/10.20448/2003.81.25.37>
- Nulty, D.D. (2008). The adequacy of response rate to online and paper surveys: what can be done? *Assessment & Evaluation in Higher Education*, 33(3), 301-314. <https://doi.org/10.1080/02602930701293231>
- Ocak, M. A. (2005). Mathematics teachers' attitudes toward the computers. *The Turkish Online Journal of Educational Technology*, 4(3), 11, 82 – 88.
- Omoniyi, T., & Quadri, A.T. (2013). Perceived competence of Nigerian secondary schools teacher in the use of information and communication technology (ICT). *Journal of Education and Practice*, 4(10), 157-164.
- Onasanya, S.A., Shehu, R. A., Oduwaiye, R.O., & Shehu, L.A. (2010). Higher institutions lecturers' attitude towards integration of ICT into teaching and research in Nigeria. *Research Journal of Information Technology*, 2, 1-10. <https://doi.org/10.3923/rjit.2010.1.10>
- Osborne, J.W., & Costello, B.A. (2004). Sample size and subject to item ratio in principal components analysis. *Practical Assessment, Research & Evaluation*, 9(11). <http://PAREonline.net/getvn.asp?V=9&n=11>
- Papanastasiou, E.C., & Angeli, C. (2008). Evaluating the use of ICT in education: psychometric properties of the survey of factors affecting teachers teaching with technology (SFA-T3). *Educational Technology & Society*, 11(1), 69-86.

- Player-Koro, C. (2012). Factors influencing teachers' use of ICT in education. *Education Inquiry*, 3 (1), 93-108.
- Rahimi, M., & Yadollahi, S. (2011). ICT use in EFL classes; a focus on EFL teachers' characteristics. *World Journal of English Language*, 1(2), 17-29. <https://doi.org/10.5430/wjel.v1n2p17>
- Rajasekar S., & Raja, P. V. (2007). Higher secondary school teachers' computer knowledge and their attitude towards computer. *E-Journal of All India Association for Educational Research*, 19 (1&2). <http://www.aiaer.net/ejournal/vol19107/18.htm>
- Rastogi, A., & Malhotra, S. (2013). ICT skills and attitudes as determinants of ICT pedagogy integration. *European Academic Research*, 1(3), 301-318.
- Ringle, C.M., Sarstedt, M., & Straub, D.W. (2012). A critical look at the use of PLS-SEM in MIS Quarterly. *MIS Quarterly*, 36(1), iii-xiv
- Ross, J.A., Hogaboam-Gray, A., & Hanney, L. (2001). Effects of teacher efficacy on computers skills and computer cognitions of Canadian students in Grades K-3. *The Elementary School Journal*, 102(2), 141 – 156.
- Sang, G., Valcke, M., van Braak, J., & Tondeur, T. (2009). Investigating teachers' educational beliefs in Chinese primary schools: socioeconomic and geographical perspectives. *Asia-Pacific Journal of Teacher Education*, 37(4), 363 – 377.
- Sang, G., Valcke, M., van Braak, J., & Tondeur, T. (2010). Student teachers' thinking processes and ICT integration: predictors of prospective teaching behaviours with educational technology. *Computers & Education*, 54(1), 103-112. <https://doi.org/10.1016/j.compedu.2009.07.010>
- Sang, G., Valcke, M., van Braak, J., Tondeur, T., & Zhu, C. (2011). Predicting ICT integration into classroom teaching in Chinese primary schools: exploring the complex interplay of teacher-related variables. *Journal of Computer Assisted Learning*, 27(2), 160–172. <https://doi.org/10.1111/j.1365-2729.2010.00383.x>
- Santos, J.R.A. (1999). Cronbach Alpha: a tool for assessing the reliability of scales. *Journal of Extension*, 37 (2). <http://www.joe.or/joe/1999april/tt.3.php?ref>
- Shin, W.S., Han, I., & Kim, I. (2014). Teachers' technology use and the change in their pedagogical beliefs in Korean educational context. *International Education Studies*, 7(8), 11-22. <https://doi.org/10.5539/ies.v7n8p11>
- Smeets, E., van Gennip, H., & van Rens, C. (2009). Teaching styles of teacher educators and their use of ICT. *Inonu University Journal of the Faculty of Education*, 10(3), 49-62
- Taylor, R. (1990). Interpretation of the correlation coefficient: a basic review. *Journal of Diagnostic Medical Sonography*, 1 (6), 35-39.
- Teo, T. (2009a). Modeling technology acceptance in education: a study of pre-service teachers. *Computers & Education*, 52(1), 302-312.
- Teo, T. (2009b). Examining the relationship between student teachers' self-efficacy beliefs and their intended uses of technology for teaching: a structural equation modeling approach. *The Turkish Online Journal of Educational Technology*, 8(4), 1, 7-16.

- Teo, T. (2010). Examining the influence of subjective norm and facilitating conditions on the intention to use technology among pre-service teachers: a structural equation modeling of an Extended Technology Acceptance Model. *Asia Pacific Education Review*, 11, 253-262.
- Teo, T., Chai, C.S., Hung, D., & Lee, C.B. (2008). Beliefs about teaching and uses of technology among pre-service teachers. *Asia Pacific Journal of Teacher Education*, 36 (2), 163-174.
- Teo, T., & Koh, J. H. L. (2010). Assessing the dimensionality of computer self-efficacy among pre-service teachers in Singapore: a structural equation modeling approach. *International Journal of Education and Development using Information and Communication Technology*, 1(6), 3, 7-18.
- Teo, T., Lee, C.B., & Chai, C.S. (2008). Understanding pre-service teachers' computer attitudes: applying and extending the technology acceptance model. *Journal of Computer Assisted Learning*, 24, 128-143.
- Tondeur, J., Valcke, M., & van Braak, J. (2008). A multidimensional approach to determinants of computer use in primary education: teacher and school characteristics. *Journal of Computer Assisted Learning*, 24, 494-506.
- Tondeur, J., van Braak, J., & Valcke, M. (2007). Towards a typology of computer use in primary education. *Journal of Computer Assisted Learning*, 23, 197-206.
- Tsai, C.-C., Chuang, S.C., Liang, J.C., & Tsai, M.-J. (2011). Self-efficacy in Internet-based learning environment: a literature review. *Educational Technology & Society*, 14(4), 222-240.
- UNESCO (2008). ICT competency standards for teachers: Policy framework. <http://unesdoc.unesco.org/images/0015/001562/156210E.pdf>
- UNESCO Bangkok. (2005). Regional guideline on teacher development for pedagogy technology integration. [http://www.unescobkk.org/fileadmin/user\\_upload/ict/e-books/Draft\\_Regional\\_Guidelines/Regional\\_guidelines.pdf](http://www.unescobkk.org/fileadmin/user_upload/ict/e-books/Draft_Regional_Guidelines/Regional_guidelines.pdf)
- Van de Schoot, R., Lugtig, p., & Hox, J. (2012). A checklist for testing measurement invariance. *European Journal of Development Psychology* [Online]. <https://doi.org/10.1080/17405629.2012.686740>
- Venkatesh, V., Morris, M. G., & Davis, F. D. (2007). Dead or Alive? The development, trajectory and future of technology adoption research. *Journal of the Association for Information Systems*, 8(4), 9, 267-286.
- Venkatesh, V., Morris, M. G., Davis, G. B., & Davis, F. D. (2003). User acceptance of information technology: toward a unified view. *MIS Quarterly*, 27(3), 425-478.
- Westland, C.J. (2010). Lower bounds on sample size in Structural Equation Modeling. *Electronic Commerce Research and Applications*. <https://doi.org/10.1016/j.elerap.2010.07.003>
- Windschitl, M., & Sahl, K. (2002). Tracing teachers' use of technology in a laptop computer school: The interplay of teacher beliefs, social dynamics, and institutional culture. *American Educational Research Journal*, 39(1), 165-205.
- Woolley, S. L., Benjamin, W. J. J., & Woolley, A. W. (2004). Construct validity of a self-report measure of teacher beliefs related to constructivist and traditional approaches to teaching and learning. *Educational and Psychological Measurement*, 64, 319-331. <https://doi.org/10.1177/0013164403261189>

Wozney, L., Venkatesh, V., & Albrini, P.C. (2006). Implementing computer technologies: teachers' perceptions and practices. *Journal of Technology and Teacher Education*, 14(1), 173-207

Yilmaz, E., & Ozer, G. (2013). Behavioural aspect of accounting teachers' information technology usage. *International Review of Economics and Management*, 1(2), 108-121.